

GLOBAL LOW VOLUME AIR SAMPLING SYSTEM F&J MODEL GAS-CB-22

NOTABLE FEATURES:

- State-of-the-Art Electronics
- Powerful: Flow rate to 140 LPM*
- Very low maintenance
- Automatic Flow Control
- Precision machined DP flow sensor
- Bright OLED Display; 4 lines x 32 characters
- Dual RS-232 communication ports
- Flow rate accuracy: $\pm 3.0\%$ Full Scale
- Auto zero calibration feature of flow sensor
- Multiple operator selectable data storage and data transmission frequency rates
- Wide temperature range electronics
- Brushless motor; 12VDC

* Dependent upon filter paper dimensions and air flow resistance



External Sample Inlet with Rain Shield is an option for WH-3 Weather House

GENERAL DESCRIPTION:

F&J Model GAS-CB-22 is a powerful small foot print light weight AC/DC powered air sampling system operable from (1) line power, or (2) an optional 12VDC external power source.

The GAS-CB-22 air sampler is a microprocessor controlled low volume REMP air sampling system consisting of a low maintenance brushless motor and centrifugal vacuum system. The air sampler component is very light (~ 15 lbs.) and requires no maintenance. It can also be utilized in remote air sampling applications powered from solar panels, or a wind turbine. The Global Air Sampler software provides the ultimate in end user customization including operator selectable alarm settings, Reference T and P values and engineering units. A feature rich data acquisition and report writing PC program is an optional item.

The F&J technology provides maximum flexibility, data integrity, automatic flow control and opportunities for control by a PC device through the RS232 communication port.

The typical operating flow range is 20 - 140 SLPM (0.7 – 5 SCFM). Actual achievable maximum flow will depend on the filter(s) utilized by the customer.

GAS-CB-22 Air Sampler Specifications

Pump Type: Centrifugal blower

Motor: 12VDC; 60,000 rpm

Maximum Flowrate:

140 LPM - Typical w/47 mm FP47M glass fiber media

Power Source:

Line Power; 100VAC to 120VAC

External DC Source – 12VDC

Current Draw:

2 A maximum on line power

9 A maximum on 12VDC

Filter Holder Fitting:

3/8 FNPT quick disconnect

Weight:

~ 82 lbs. (37.3 kg)

Dimensions:

32" × 26" × 48¼"

(81.3 × 66 × 122.6 cm)

Operating Temperature Range:

14°F to 122°F (-10°C to 50°C)

Display:

Bright OLED Display; 4 lines x 32 characters

Flow Control:

Adjustable from keypad between 20-140 LPM

Flow Accuracy:

±3.0% of Full Scale

Communication Interface: Dual RS-232

Operator Selectable Features

Language Options: English

Sampling Mode: Volumetric Flow or Mass Flow

Gas Type: Air, O₂, N₂, H₂, CO, CO₂, C₃H₆, He, NH₃

Engineering Units

Volumetric Flow: sccm, SLPM, SCFM, sm³/min, sm³/hr

Mass Flow: kg/hr, g/min, 1 lbs/hr

Temperature: °C, °F

Pressure: In Hg, mm Hg, bar, atm, kPa

Reference T and P

Reference T: 0°C, 15°C, 20°C, 21.1°C (70°F), 25°C

Reference P: 101.325 kPa (760 mm Hg), 100 kPa (1 bar)

RS232 Data Output Frequency: 1 sec, 1 min, 10 min, 20 min, 30 min, 1 hr

Data Storage Frequency: 1 min, 10 min, 20 min, 30 min, 1 hr

Operating Mode: Continuous, or Periodic

Periodic Sampling Options: Weekly (24 one hour periods for 7 days)

Ending Mode: By time, By volume

Operator Selectable Passwords: 2 levels

Date and Time Setup: Input of real time and date

Standard Combination Filter Holders Available:

FILTER HOLDER MODEL	CHARCOAL CARTRIDGE DIMENSIONS	PARTICULATE PAPER DIAMETER
FJ-05P	F&J Model B	2" or 50 mm
FJ-21P	F&J Model C	2" or 50 mm
FJ-35P	F&J Model B	47 mm
FJ-46P	F&J Model C	47 mm
FJ-51P	F&J Model M	2" or 50 mm
FJ-53P	F&J Model M	47 mm

Software:

- Air Sampler Data Acquisition Program
P/N: GASdaq

Maximum Flow Rates for Various NPP Type Particulate and Charcoal Cartridges

Filter Media Type	Maximum Flow Rate (L/min)	Maximum Flow Rate (ft ³ /min)
FP-47	80.6	2.8
FP47 + TE2C	65.5	2.3
FP47 + TE3C	74	2.6
FP47M	148.1	5.2
FP47M + TE2C	98.1	3.4
FP47M + TE3C	117.5	4.1
521147	87.4	3.1
521147 + TE2C	69.8	2.5
521147 + TE3C	77.7	2.7

Environmental Air Sampling System Designed for Continuous Outdoor Use

1. Available in WH-3 weather house or larger optional WH-3A enclosure.

2. Air sampler component can be easily exchanged for laboratory calibration, or maintenance.

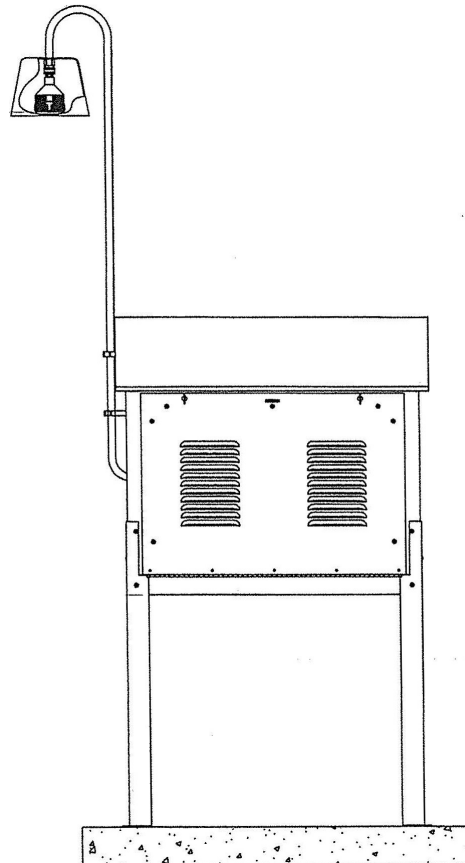

3. Air sampler component can also be used as a light weight portable air sampler.

CONSUMABLES AND ACCESSORIES FOR AIR MONITORING PROFESSIONALS

Assorted Filter Paper



Cellulose, Quartz, Membrane and Glass Fiber

Filter Holders



Plastic



Aluminum

Radioiodine Collection Cartridges



TEDA Impregnated Charcoal Cartridges and Silver Zeolite Cartridges